

## JOLLY TOP

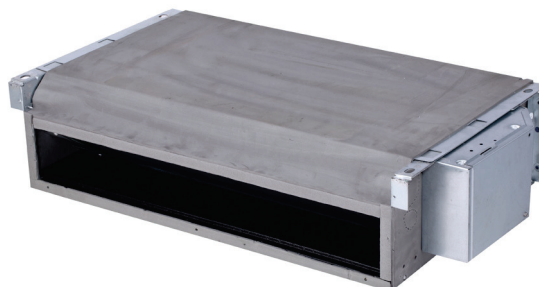
- **I-VM VENTILCONVETTORE CON MOTORE INVERTER PER INSTALLAZIONE A VISTA** / FANCOIL WITH DC INVERTER MOTOR FOR EXPOSED INSTALLATION / FANCOIL TIPO MUEBLE CON MOTOR INVERTER / VENTILCO-CONVECTEUR DE TYPE MEUBLE AVEC MOTEUR INVERSEUR / VENTILOCOVECTOR TIPO MÓVEL COM MOTOR INVERTER
- **I-VN VENTILCONVETTORE CON MOTORE INVERTER PER INSTALLAZIONE CANALIZZATA** / FANCOIL WITH DC INVERTER MOTOR FOR DUCTED INSTALLATION / FANCOIL TIPO CONDUCTO CON MOTOR INVERTER / VENTILCO-CONVECTEUR GAINABLE AVEC MOTEUR INVERSEUR / VENTILOCOVECTOR TIPO CONDUCTA COM MOTOR INVERTER
- **3V-VM VENTILCONVETTORE CON MOTORE A 3 VELOCITÀ PER INSTALLAZIONE A VISTA** / FANCOIL WITH 3-SPEEDS MOTOR FOR EXPOSED INSTALLATION / FANCOIL TIPO MUEBLE CON SELECTOR DE 3 VELOCIDADES / VENTILCO-CONVECTEUR TYPE MEUBLE AVEC MOTEUR À 3 VITESSES / VENTILOCOVECTOR TIPO MÓVEL COM SELECTOR DE 3 VELOCIDADES
- **3V-VN VENTILCONVETTORE CON MOTORE A 3 VELOCITÀ PER INSTALLAZIONE CANALIZZATA** / FANCOIL WITH 3-SPEEDS MOTOR FOR DUCTED INSTALLATION / FANCOIL TIPO CONDUCTO CON SELECTOR DE 3 VELOCIDADES / VENTILCO-CONVECTEUR GAINABLE AVEC MOTEUR À 3 VITESSES / VENTILOCOVECTOR TIPO CONDUCTA COM SELECTOR DE 3 VELOCIDADES



Cod. 3QE46280 - Rev. 00 - 06/2020



I-VM / 3V-VM



I-VN / 3V-VN



**IT** MANUALE DI INSTALLAZIONE, MANUTENZIONE E USO

**EN** INSTALLATION, MAINTENANCE AND USER MANUAL

**ES** MANUAL DE INSTALACIÓN Y FUNCIONAMIENTO

**FR** MANUEL D'UTILISATION ET D'INSTALLATION

**PT** MANUAL DE INSTRUÇÕES E DE INSTALAÇÃO

# CONTENTS

---

<b>1 PRODUCT OVERVIEW</b>	01
<b>2 WARNING</b>	
• 2.1 Meaning of various labels	02
• 2.2 Warning	02
• 2.3 Note	02
• 2.4 Information	03
<b>3 OPERATION INSTRUCTIONS</b>	
• 3.1 Standard conditions for use	03
• 3.2 Switch and control	03
• 3.3 Air supply direction adjustment	05
<b>4 CLEANING AND MAINTENANCE</b>	
• 4.1 Maintenance by customer	05
• 4.2 Professional maintenance	06
<b>5 INSTALLATION INSTRUCTIONS</b>	
• 5.1 Packaging and assembly	08
• 5.2 Handling instructions	08
• 5.3 Installation	08
• 5.4 Liquid pipe connections	11
• 5.5 Electrical connection	13
• 5.6 Startup guide	16
<b>6 SERVICE GUIDE</b>	
• 6.1 Troubleshooting	16
• 6.2 Non-unit related faults	17
• 6.3 Product data	18

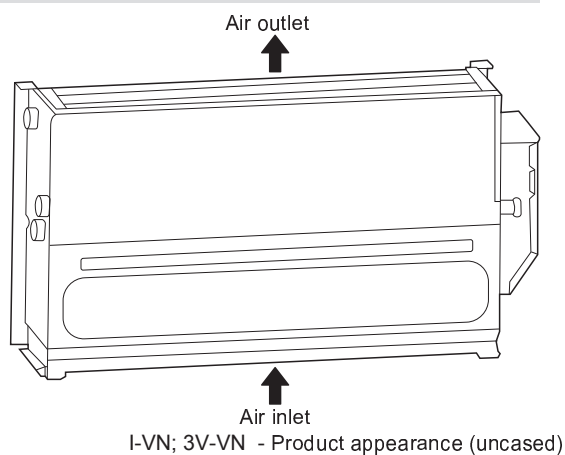
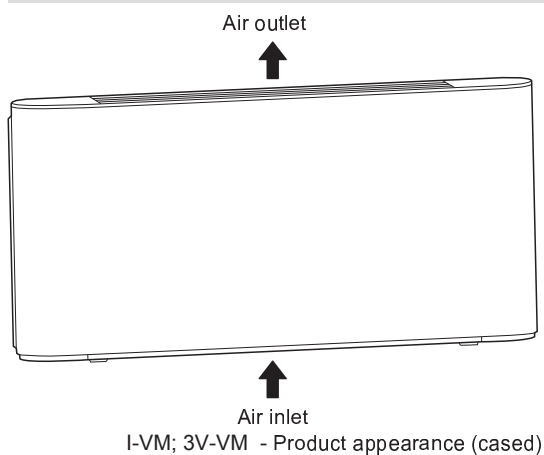
---

## 1 PRODUCT OVERVIEW

This ceiling & floor type unit is used for indoor air quality regulation in various scenes. It is intended to be used by expert or trained users in shops, in light industry and on farms, or for commercial use by lay persons.

### NOTE

The figures here are for reference only and may have differences with the actual product you received.



NO.	Name	Schematic	Unit	Qty	Remarks
1	Operation and Installation Manual		Pcs	1	Accessories
2	Fastening screw		Pcs	4	To be purchased separately
3	Three-way valve and its piping assembly		Set	1	To be purchased separately from the manufacturer
4	Footing		Set	1	To be purchased separately from the manufacturer
5	Auxiliary drain pan		Pcs	1	To be purchased separately from the manufacturer
6	Wired controller		Pcs	1	To be purchased separately
7	Inlet hose		Pcs	1	To be purchased separately
8	Outlet hose		Pcs	1	To be purchased separately
9	Filter		Pcs	1	To be purchased separately
10	Check valve (inlet and outlet pipes)		Pcs	2	To be purchased separately
11	Drain pipe		Pcs	1	To be purchased separately

## 2 WARNING

This section describes important safety information.

Please read the Manual carefully, especially those operating standards with "Warning" or "Note" signs. Failure to abide by these standards may lead to personal injury or damages to the unit or other items.

For any faults not covered by the Manual, please contact the manufacturer immediately.

Tampering with the unit can result in very hazardous situations. The manufacturer does not accept liability for damage resulting from unauthorized or inappropriate changes to the product.

## 2.1 Meaning of various labels

### WARNING

A situation that may lead to death or injury.

### NOTE

A situation that may cause damage to the unit or loss of property.

### INFORMATION

Indicates a useful hint or additional information.

## 2.2 Warning

- Ask qualified professional staff to install (install for the first time, change the place of the unit or re-install) and repair the unit and its parts. Do not attempt to install or repair the air conditioner by yourself, as any improper operations may lead to fire, electric shock, personal injury or water leakage.
- Make sure the unit is grounded reliably in accordance with the laws. Otherwise, it may cause electric shock.
- Stop using the air conditioner and consult your dealer in case of any abnormalities. Otherwise, fire or electric shock may occur.
- Do not attempt to maintain or alter the unit by yourself. Improper operations may cause water leakage, electric shock or fire.
- Make sure the leakage protection device is installed, or electric shock may occur.
- Do not wash the unit with water, or electric shock may occur.
- To avoid electric shock, do not place any water-filled container on the unit.
- Do not operate the switch with wet hands, or electric shock may occur.
- Do not put your fingers or other objects into the unit, it can result in serious injury.
- Do not obstruct the air supply channel, as that may result in personal injury or damages to the unit.
- Check that the supporting structure of the unit is securely installed after a long period of use, to prevent fall accidents.
- Make sure the installation base and hoisting are robust and reliable; otherwise, the unit may fall and lead to accidents.
- Do not expose yourself to cold air over a long period. Too low temperature may cause harm to your health.
- Do not expose animals or plants to air outlet to avoid any harm.
- This unit is intended for air handling only. Do not use it for animal rearing.

- Do not install the unit where flammable gas may leak. Otherwise, fire may occur. Do not install the unit in potentially explosive atmospheres.
- Keep the unit far away from combustible spray to avoid fire.
- Use proper fuse. Do not use iron wire or copper wire, as it may cause fire or unit abnormality.
- When connecting power supply to the unit, follow the regulations of the local electric company.
- Provide separate power switch to ensure the unit can be disconnected from power properly.
- Do not use this unit to store spare parts or other items.
- Please attach enough importance to the signs and symbols indicated on the unit. Any other potential hazards not covered in the Manual (if any) should be specified in labels attached to the unit.
- For safety concerns, only the manufacturer or its service agent or a similarly qualified person can replace a damaged wire.

## 2.3 Note

- Read the Manual carefully and perform a safety inspection in advance so that you can be fully aware of the possible dangers as you use or install the unit.
- The manufacturer shall not be liable for any personal or animal injury or damage to any object caused by incorrect installation, adjustment, maintenance or improper use.
- The manufacturer is not held liable for any damages resulting from faulty operations against this Manual.
- Do not expose this unit to wet or humid environments as this may damage the electrical components.
- Do not store this unit in the open air. Do not stack unpackaged units.
- Do not use this unit to store food, plants, precision instruments, artwork, etc.
- To operate the unit for the first time, exhaust the air in the coil; otherwise, the performance may be compromised.
- Clean the inside of the water pipe before use.
- Remember to implement anti-freezing measures for coil in winter. For details, please refer to anti-freezing instructions herein.
- Keep the unit energized even if it is not in service over a long period.
- Adopt self-protection measures when you install, maintain or clean the unit.
- Do not press the unit. Handle it carefully as any damages may cause unit malfunction.
- Reserve enough space for installation and maintenance.
- Before installation, check whether the unit is reliably grounded. Otherwise, do not proceed with the installation. In no circumstances can the earth line for main power switch be disconnected.
- Rotate the fan impeller during installation. Contact the manufacturer if you hear any abnormal noises.

- Make sure that the water discharge pipeline can provide smooth drainage. Improper installation of the water discharge pipeline may lead to water leakage, and damages to furniture.
- Make sure the liquid pipeline and air duct are reliably supported. Make sure pipes and connectors are not distorted.
- The water inlet and outlet pipes must have check valves installed and be wrapped with insulation materials.
- Connect the wires as required. Otherwise, it may cause damage to electrical parts.
- The actual power supply must be consistent with the nominal nameplate value, or permanent damage may occur.
- Use power cord with a proper diameter.
- Do not use damaged cables. Replace the damaged cables immediately if necessary. Do not attempt to repair the damaged cables.
- Keep for future reference.

## 2.4 Information

- Keep the unit serial number available for future reference and in case when you need to contact the after-sales service.
- Do not bring any combustible materials near the air outlet.
- Transport the unit as per requirements indicated on the package.
- Avoid crash, fall-over or squeeze and keep away from rain and snow during transportation.
- Store the unit in a clean, dry, fire-proof and well-ventilated place without any corrosive gas.
- To avoid shock during transportation, fix the unit and its accessories on the transportation platform with ropes or by other means.

## 3 OPERATION INSTRUCTIONS

This appliance can be used by children aged 8 and above and persons with reduced physical, sensory or mental capabilities or lack of experience and knowledge if they have been given supervision or instruction concerning use of the appliance in a safe way and understand the hazards involved.

Cleaning and maintenance shall not be made by children without supervision.

- The manufacturer is not responsible for unit damages or personal injury resulting from unauthorized operations or use of non-original parts or accessories.
- **Ventilation**  
Periodically ventilate the room where the unit is installed. Ventilation is especially important in case the room has many people in it or has flammable devices or gas sources. Poor ventilation may result in lack of oxygen.
  - Before unit operation, clean water pipes to prevent them from being blocked.
  - Upon FCU test run or switching between hot and cold water, open the vent valve to exhaust air in the coil until water flows out. Otherwise, the heat exchange performance may be significantly compromised.
- **During operation**  
Filter is normally not removed except for maintenance purpose, as doing so may cause foreign objects to enter the unit.

- **In normal cases**

In cooling mode, fog may appear at the air outlet.

### 3.1 Standard conditions for use

Use the unit in the following temperature range for safe and effective operation.

Mode	Indoor temperature
Cooling	17-32°C
Heating	0-30°C

The unit can achieve optimum performance when running within the temperature range listed above. At a temperature beyond the listed ranges, unit faulty may occur.

The unit can only operate normally as long as you strictly adhere to the regulations outlined in the Manual.

Water inlet temperature range is 3-75°C.

Water inlet temperature range recommended is 3-65°C.

Water inlet pressure range is 0-1.6MPa.

### 3.2 Switch and control

The wired controller should be purchased separately from the manufacturer. Other wired controllers are not applicable.

#### Installation position of wired controller

You can install the wired controller on the left, or right of the unit or on the wall as required. Make sure the wired controller is close to the electric control box.

Please refer to the Wired Controller Operation and Installation Manual for installation methods.

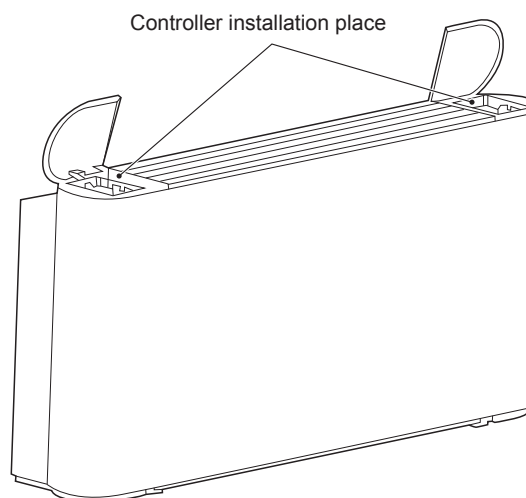


Figure 3-1 Installation position of wired controller

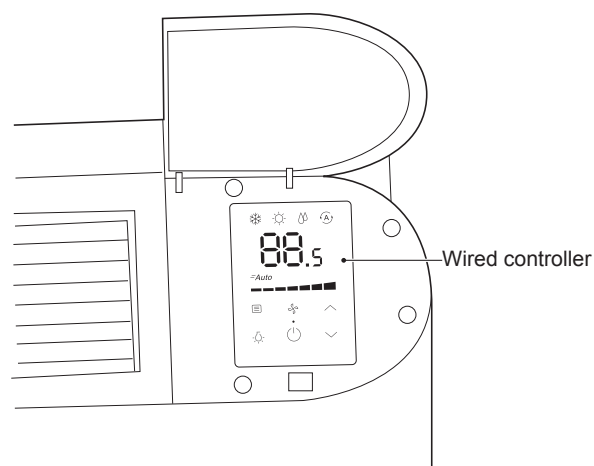


Figure 3-2 After installation of wired controller  
(only for I-VM units)

The Operation Manual is provided with the wired controller.

You can complete the following operations using the manufacturer's wired controller:

Start/stop the unit.

Switch between seven fan speeds and auto.

Constant temperature set within a desired range.

Switch among Cool, Heat, Dry, and Auto.

0-10V wired controller output DC voltage signal to main board. The main board receives the signal and controls the motor according to the corresponding speed.

Table 3-1 (I-VM) 0-10V wired controller output signal specification

	Controller output voltage	Fan speed
Seven fan speeds	$0 \leq \text{Voltage} < 1$	Shutdown
	$1 \leq \text{Voltage} < 3$	Low
	$3 \leq \text{Voltage} < 4$	Medium low
	$4 \leq \text{Voltage} < 5$	Medium
	$5 \leq \text{Voltage} < 6$	Medium high
	$6 \leq \text{Voltage} < 7$	High
	$7 \leq \text{Voltage} < 8$	Super high
	$8 \leq \text{Voltage} < 10$	Strong
Auto speed	The wired controller is adjusted according to the logic of the seven-level control system.	

## 1) Start and stop

Start or stop the unit using the wired controller or centralized controller.

<p>① Start the unit after it has not been used for a long time</p>	<p>Before starting the unit again, you should:</p> <ul style="list-style-type: none"> <li>Clean or replace the air filter.</li> <li>Clean the heat exchanger.</li> <li>Make sure the drain pipe for drain pan of heat exchanger is clean; if not, wash it.</li> <li>Remove air from the water system.</li> </ul>
<p>② Leave the unit unused for a long period</p>	<p>If the unit is not to be used in winter, drain the water system when appropriate. Otherwise, the water in the system may freeze, thus causing damage to the unit, or leading to water leakage, electric shock or damage to furniture.</p>

### 3.3 Air supply direction adjustment

You can manually adjust the louver to change the air supply direction.

#### NOTE

Do not touch the heat exchanger to avoid any personal injury.

To adjust the air supply direction, do as follows:

- 1) Remove the screws (M3.9\*10) fixing the louver.
- 2) Disassemble the louver manually.
- 3) Rotate the louver by 180° and then put it back manually.
- 4) Put the screws back and fasten them.

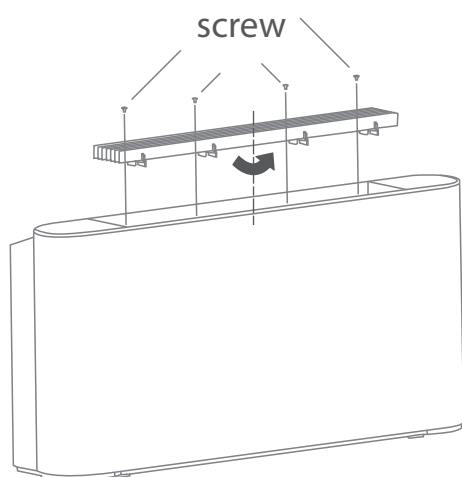


Figure 3-3 Adjusting the air supply direction

## 4 CLEANING AND MAINTENANCE

### 4.1 Maintenance by customer

#### NOTE

Cleaning and maintenance must not be performed by minors without supervision.

Cleaning the outer surface of the unit is permitted. Dip a piece of soft cloth in cold water and alcohol to clean the unit. Do not use hot water, solvent, abrasive or corrosive substances.

#### NOTE

Disconnect the unit from power supply before cleaning or maintenance.  
Do not spray water on the unit.

### 1) Cleaning the air filter

To ensure proper air return, clean the air filter at least once every month. If used in a dusty environment, the filter must be cleaned on a more frequent basis. Take the air filter out before you can clean it.

The filter is at the bottom of the unit, while the air return outlet is at the bottom or the rear side.

To take the air filter out, do as follows:

- a) Remove the screws ① and ②.
- b) Rotate the filter bracket.
- c) Pull out the filter.

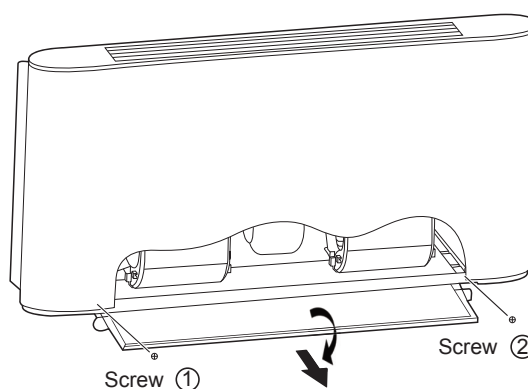


Figure 4-1 Removing the filter

Blow the air filter with compressed air or clean it in water.

Before putting the filter back, make sure it is clean and dry. If it is damaged, replace it with a new one.

## 4.2 Professional maintenance

### 4.2.1 Structure

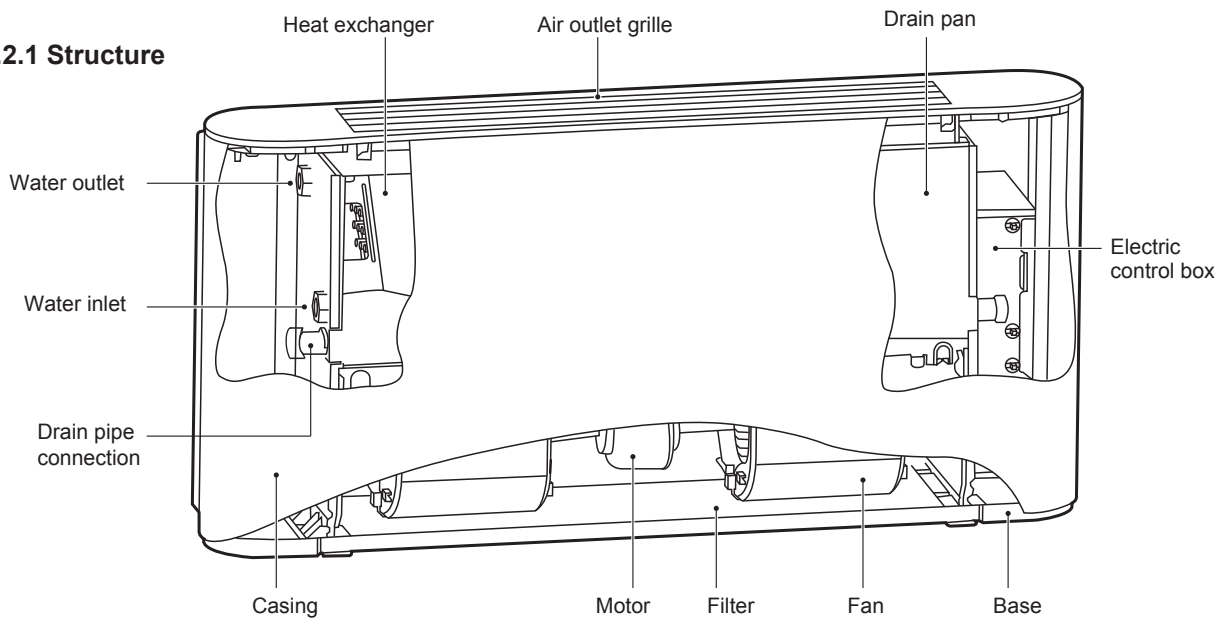


Figure 4-2 Unit cased

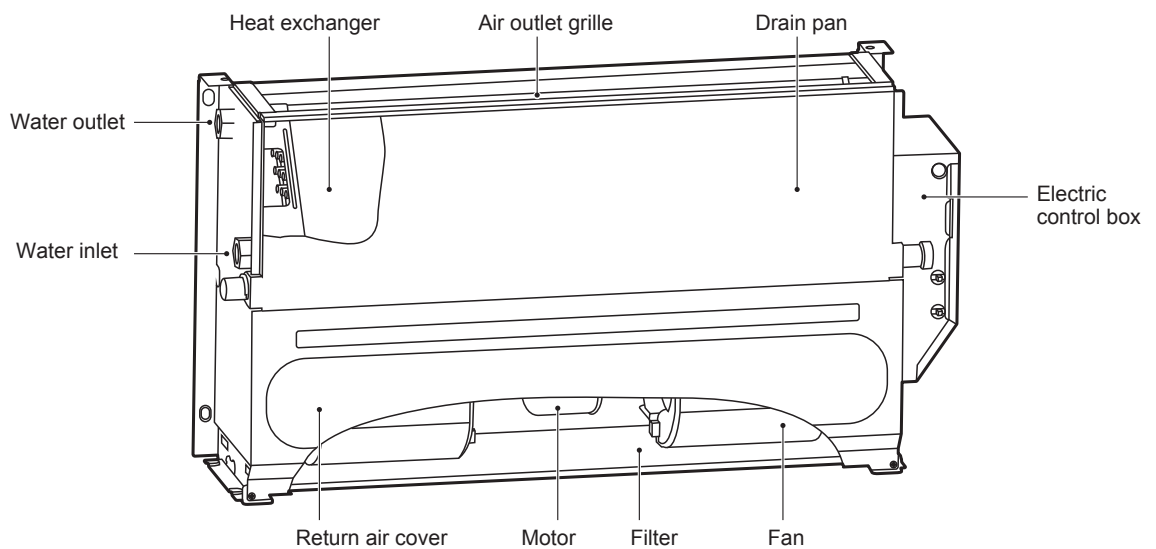


Figure 4-3 Unit uncased

For dual-pipe system and four-pipe cold water coil, the water inlet and outlet joints are G3/4. For four-pipe hot water coil, the water inlet and outlet joints are G1/2.

The casing of the unit is made of galvanized steel; the air filter is made of nylon fibre, and the aluminum alloy air filter can be customized; the motor has internal overheat protection and overcurrent protection; a centrifugal rotating fan is used; a soundproof material such as sponge is used; the fin type heat exchanger is composed of copper pipe and aluminum foil, and the heat exchanger pipe connection can be changed on site.

### 4.2.2 Maintenance

#### NOTE

Only qualified technicians who have unit and refrigeration system experience can perform maintenance operation. Proper gloves are required.

Before maintenance or check, disconnect the unit from power supply, keep the main switch closed with warning sign attached, to prevent others from resuming the power accidentally.

#### 1) Routine maintenance

#### 2) Once every month

Check whether the air filter is clean. The air filter is washable as it is made of fibre. When the unit is operational, make sure you check the air filter every month.

#### 3) Once every six months

Check whether the heat exchanger and condensate drain pipe are clean. After power disconnection, disassemble the unit to check the heat exchanger and condensate drain pipe.



#### 4) If necessary, you should:

- Remove any foreign matters that may impede air flow.
- Remove the dust with compressed air or clean water and avoid damage to the heat exchanger.
- Dry with compressed air.
- Check for any impurities in the drain pipe that may impede water flow.

#### e) Check whether the system has air.

- Start and let the system run for several minutes.
- Stop the system.
- Open the air discharge valve to remove air.
- Repeat this operation until the air is exhausted.

#### 5) Maintain the circuits.

Check whether the power cord, electrical contacts, terminals, etc. are loose or damaged.

#### 6) If the motor needs to be replaced, follow the steps below:

- Unplug the unit.
- As shown in Figure 4-4, remove screws ①\*2 and ②\*2 and then the casing.
- As shown in Figure 4-5, remove screws ①\*2 to take the filter out.

Then, remove the upper volute.

After that, remove four screws (②) that fix the motor, to disconnect the motor cable and the main board. Then, take out the fan and the motor.

Disassemble the fan to get the motor.

Install back the motor in reverse order.

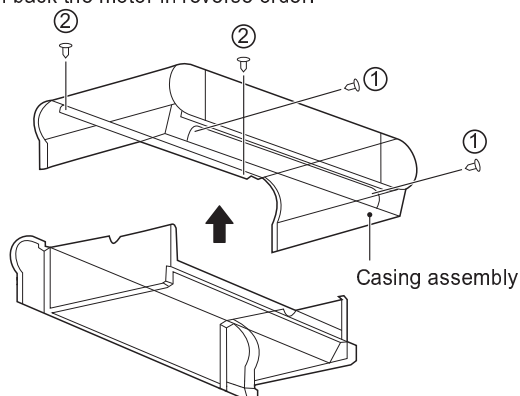


Figure 4-4 Removal of casing

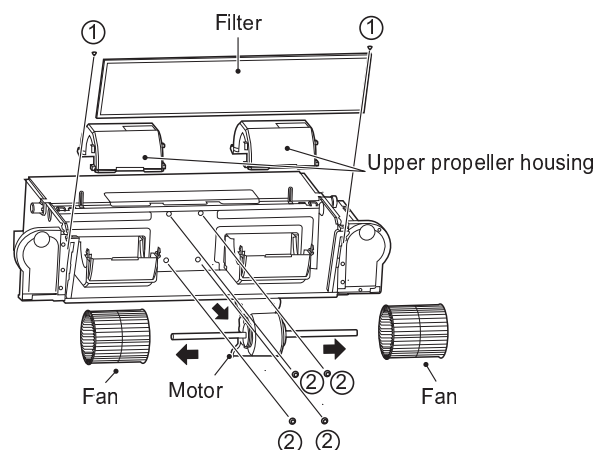


Figure 4-5 Removal of filter, upper volute and motor screws

#### 7) If the heat exchanger needs to be replaced, follow the steps below:

- Unplug the unit.
- Shut off the water supply.
- As shown in Figure 4-6, remove screws ①\*2 and ②\*2 and then the casing.
- Drain the coil.
- Disassemble the inlet and outlet pipes.
- As shown in Figure 4-7, remove screws ①\*2 to remove the electric control box.
- As shown in Figure 4-8, remove screws ①\*7 to take the drain pan out. Then, remove screws ②\*4 to take the heat exchanger out.
- Pull out the temperature sensor plug.

Install back the heat exchanger in reverse order.

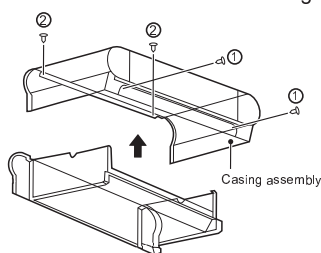


Figure 4-6 Removal of casing

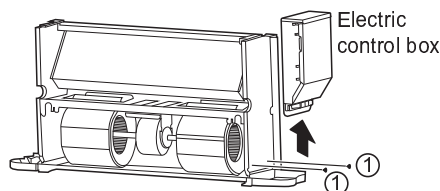


Figure 4-7 Removing the electric control box

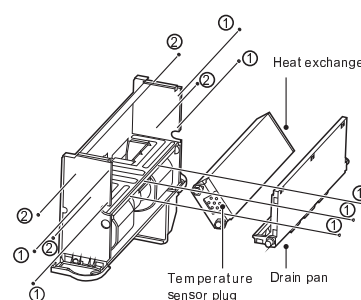


Figure 4-8 Removal of drain pan and heat exchanger

**8) If the unit or its parts need(s) to be removed, make sure that:**

Only a professional person can disassemble the unit.

The system with antifreeze must not be discarded; otherwise, it will cause pollution. It should be collected and then be disposed off properly.

As a special waste, electronic components must be handled by professional persons together with polyurethane foam, polyurethane and sound absorbing sponge.

## 5 INSTALLATION INSTRUCTIONS

### NOTE

- The instructions are applicable to IDU only.
- Customization is required for use in salty surroundings (close to the shore).
- Install the water softening device if hard water that has a high salt content is to be supplied to the coil.
- Handle with care. Do not exert too much pressure on the unit.
- Any damages to the fan, unit surface or piping may cause faults.

### 5.1 Packaging and assembly

Only trained professionals can move and lift the unit.

Upon arrival of the unit, you must check whether it is intact and provided with complete accessories. Using damaged unit may be hazardous.

**1) When removing the unit package, follow the steps below:**

Check whether the package and unit are intact and whether accessories are complete.

Unpack the unit.

Dispose off packaging materials at a suitable waste receiving or recycling station, depending on the laws of the country or locality where the installation is to be done.

Place the package out of the reach of children.

### 5.2 Handling instructions

Wear personal protective equipment during handling.

To avoid damages to external structures, internal mechanical and electrical components, caution must be exercised during handling.

Make sure there are no obstacles or pedestrians along the way in case collisions or crushing occurs or lifting or handling equipment falls over.

All of the following operations must be performed in accordance with current health and safety regulations, including the equipment used and the procedures followed. Before operation, verify that the lifting device is capable of lifting the unit.

You can lift or move the unit using your hand or using a proper handcart. For a unit that weighs over 30 kg, package it before it can be lifted using a crane or by similar means.

### 5.3 Installation

Follow the instructions when installing the unit.

Read the Manual carefully before proceeding with any operations. Installation can be only performed by a professional technician. Incorrect installation may lead to unit faults or degraded performance.

You must abide by the regulations of the country or locality where the installation is located.

Before installation, unpack the unit and its accessory, and find the attached Operation and Installation Manual and related assembly.

The support surface of installation must be strong enough to bear the weight of the unit.

Before installation, check with the customer whether the wall or ground where installation is located has buried wires, water pipes or gas pipes.

Make sure the inlet and outlet pipes and drain pipe are air-tight.

**1) Check the space technically required for installation:**

Space required for installation.

Space required for connecting the liquid lines and other valves.

Space required for connecting power supply.

Space required for connecting the unit to the external control panel (if any).

Space required for setting flow route and air inlet (for specific models).

Space required for correct and sufficient air flow.

Space required for removing condensate water.

Space required for cleaning the filter.

Space required for cleaning internal assembly and maintenance.

**2) Installation guide:**

Remove the casing:

Remove screws ①\*2 and ②\*2 and then the casing.

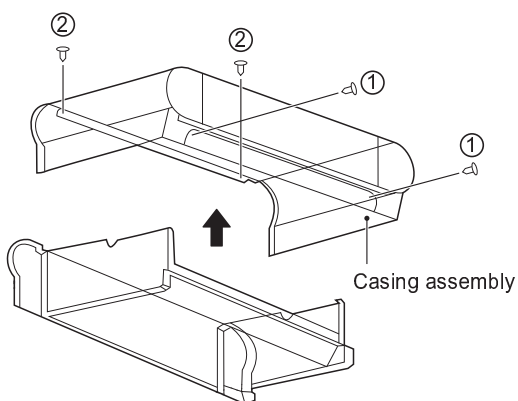


Figure 5-1

Mark the places for screws on the wall according to the unit mounting holes or dimensions specified in Figure 5-12. The drain pipe for condensate water must be smooth enough to allow unobstructed water discharge.

As shown in Figure 5-2, fasten four screws (1) into a proper masonry structure.

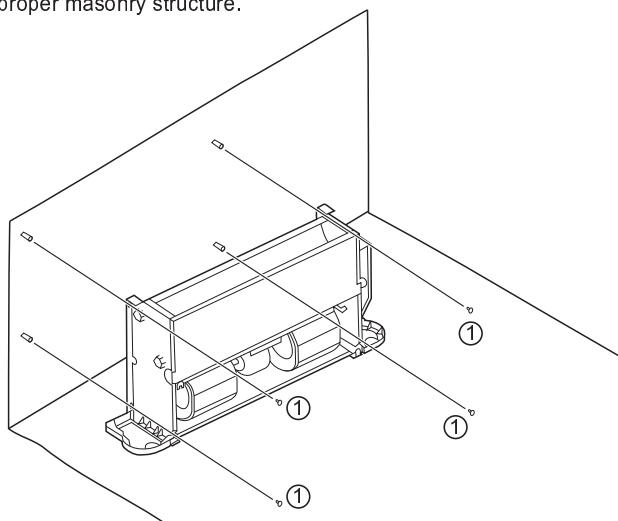


Figure 5-2 Diagram for fixing the unit body

The footings shown in Figure 5-3 are optional. You can purchase them separately and install them as follows:

1. Put the footings beside the unit to be installed.
2. Place the mounting holes on the unit base into the corresponding footing locating pin and install screws 1\*2 and 2\*2 to fix the footing according to Figure 5-3.

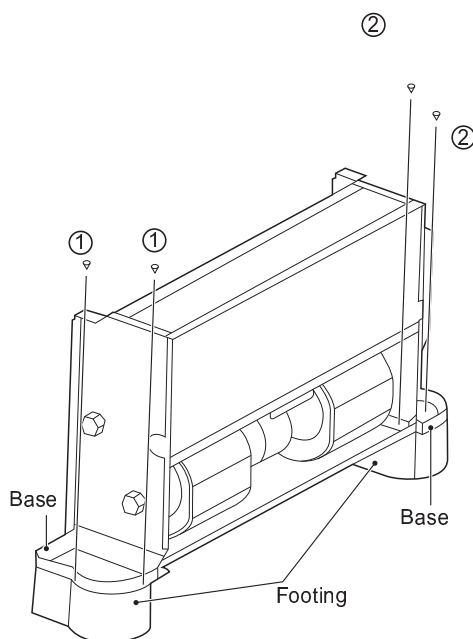


Figure 5-3

**3) Install the unit following the steps below in case it is ceiling mounted.**

To match the existing structure, set the screw pitch according to the unit dimensions.

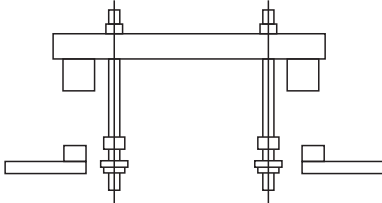
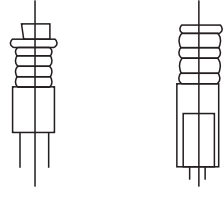
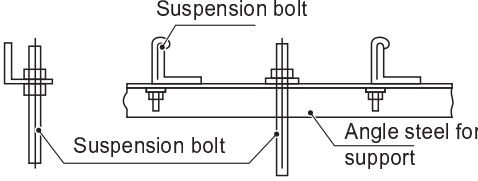
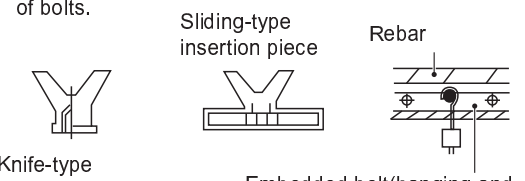
<p style="text-align: center;"><b>Wood structure</b></p> <p>Structure the square rod on the beam to set the lifting bolts.</p> 	<p style="text-align: center;"><b>Original concrete slab structure</b></p> <p>Use embedded bolts, and pull bolts.</p> 
<p style="text-align: center;"><b>Steel framework</b></p> <p>Directly set and use an angle steel for support.</p> 	<p style="text-align: center;"><b>Newly set concrete slab structure</b></p> <p>Set using embedded appliances, and embedded type of bolts.</p> 

Figure 5-4 Installation of lifting bolts

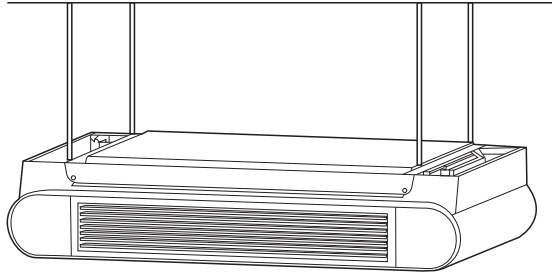


Figure 5-5 Diagram of ceiling cased

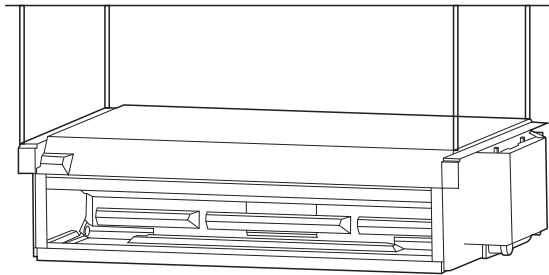


Figure 5-6 Diagram of ceiling uncased

### 5.3.1 Spacing and positioning

Incorrect positioning or installation may increase the noises and vibration of the unit during operation.

If not enough space is reserved during installation, the unit may face difficult maintenance and reduced performance.

The unit allows vertical installation, provided that correct positioning is arranged in advance. As shown below, a is greater than 150 mm, b greater than 90 mm, c greater than 50 mm and d greater than 1500 mm.

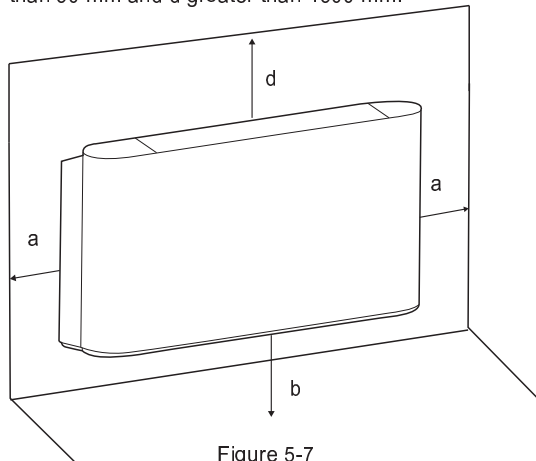


Figure 5-7

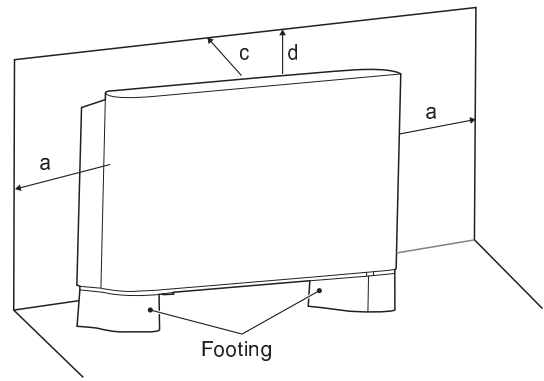


Figure 5-8

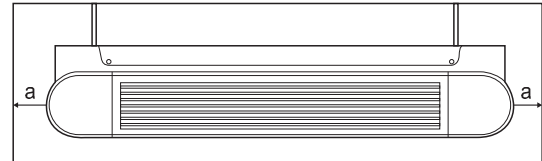


Figure 5-9 Ceiling cased

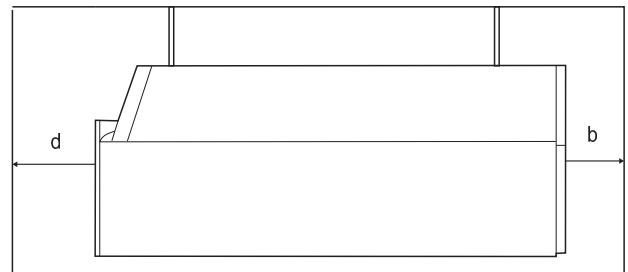


Figure 5-10 Vertical type uncased

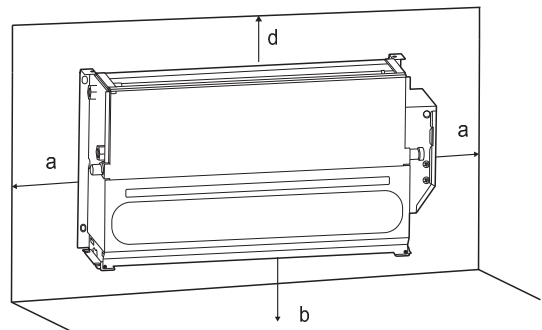


Figure 5-11 Ceiling uncased

**NOTE**

- Do not consider the unit as a surface that can be relied on during actual use. Reserve enough space during installation for ventilation purpose.
- Using water or spray near the unit can cause electric shock and malfunction.

**5.3.2 Dimensions**

DC= I-VM ; I-VN

AC= 3V-VM ; 3V-VN

Unit: mm

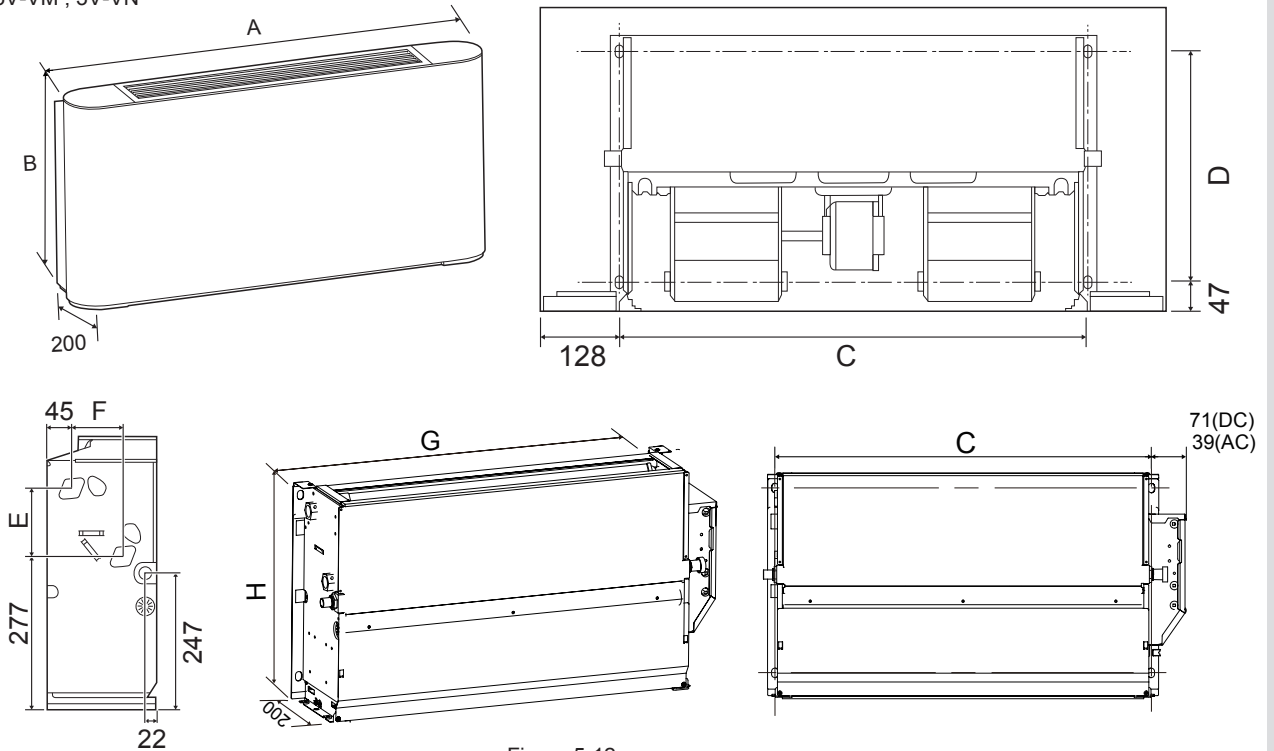


Figure 5-12

Table 5-1 Unit: mm

Model	150	250	350	500	700	800
A	790	1020	1240	1240	1360	1360
B	495	495	495	495	495	591
C	534	764	984	984	1104	1104
D	375	375	375	375	375	391
E	123	123	123	123	123	219
F	93	93	93	93	93	102
G	628	858	1078	1078	1198	1198
H	455	455	455	455	455	551

**5.4 Liquid pipe connections**

1) Only professionals can operate the liquid pipes.

Drain pipe must be the different side with the electric control box.

Connect the unit to the water system using inlet and outlet connectors.

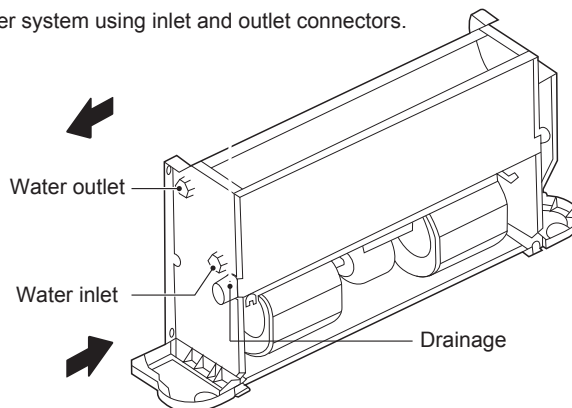


Figure 5-13

All water system coils are equipped with discharge and drain valves.

Use a screwdriver or wrench to open and close the valve.

## 2) When installation is complete,

- a) Remove air inside pipes.
- b) Wrap the connecting pipes and all the valve body with anti-condensation material (EPDM or PE) of no less than 10 mm thick or install auxiliary drainage equipment.
- c) Pour water into the drain pan and check it all the way until you can see water flows from the drain outlet. Alternatively, you may check the drain channel and remove impurities that may obstruct the flow.
- d) Install the condensate drain system.
- e) The condensate drain system must be properly lowered to ensure water discharge.

Follow the steps below to set the condensate drain system.

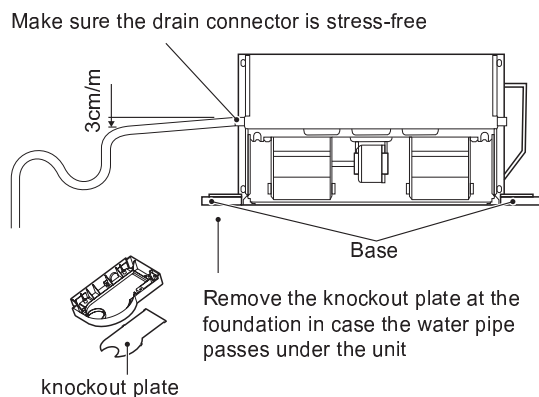


Figure 5-14

## 3) Set water storage elbow

The condensate drain system must be fitted with a suitable elbow to prevent odour penetration. Follow the steps below to set the elbow.

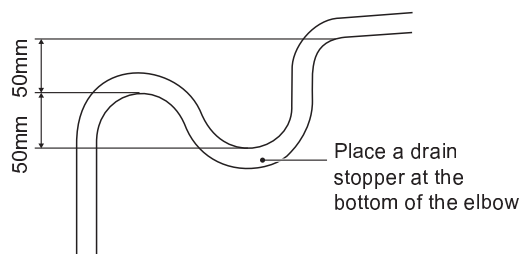


Figure 5-15

The customer has to purchase the three-way valve and its accessories (Operation and Installation Manual attached) separately from the manufacturer.

The customer may also need to purchase the auxiliary drain pan separately from the manufacturer if required. See the steps below for installation of auxiliary drain pan:

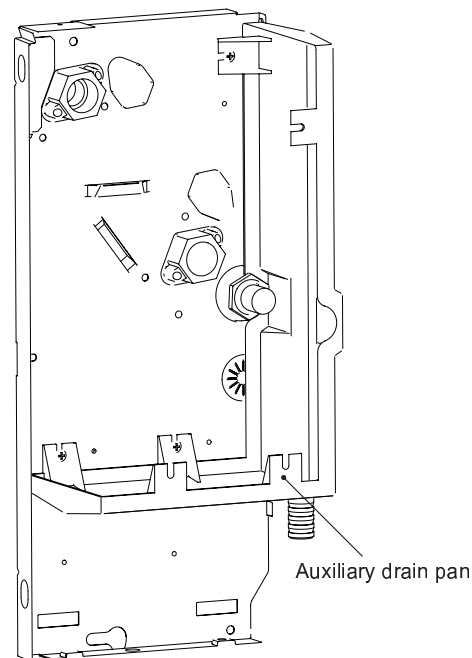


Figure 5-16

## 4) How to change the coil from left-hand connection to right-hand connection

Left-hand connection of the coil is adopted by default. You can rotate the coil and change to right-hand connection.

Before installation, you should change the direction of the coil on the ground.

Steps of changing the coil direction:

As shown in Figure 5-17, remove screws ①\*2 and ②\*2 and then the casing.

As shown in Figure 5-18, remove screws ①\*7 to take the drain pan out.

Then, remove screws ②\*4 to take the heat exchanger out.

Pull out the temperature sensor plug.

Rotate the coil in the direction as shown in Figure 5-18.

As shown in Figure 5-19, remove screws ①\*2 to take the electric box out.

Fasten the screws on the coil.

As shown in Figure 5-19, block the diamond-shaped holes on the side plate (the plate without inlet and outlet pipes) with sponge.

Reverse the direction of drain pan plug.

Re-install the electric box to the side plate without inlet and outlet pipes.

Re-connect the wires.

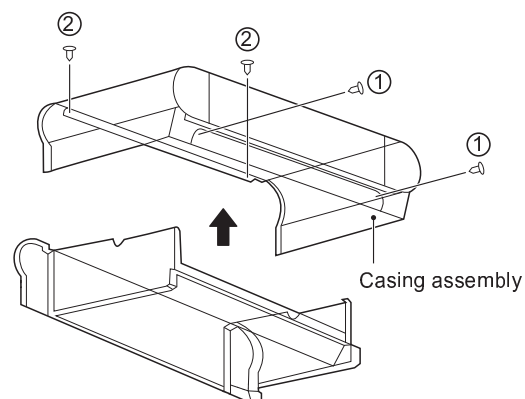


Figure 5-17 Removal of casing

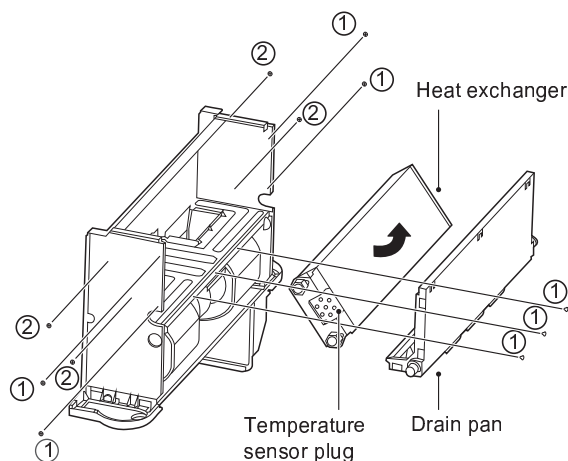


Figure 5-18

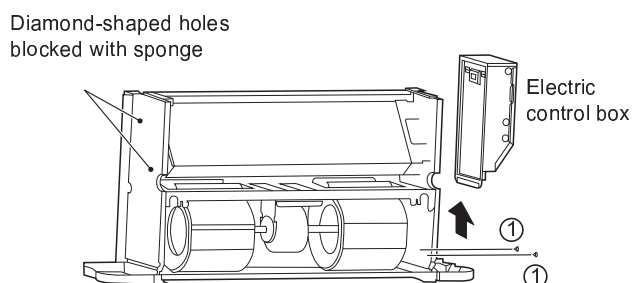


Figure 5-19 Removing the electric control box and blocking the diamond-shaped holes

### 5) Anti-freezing

The water in the unit may freeze when the unit is left unused in winter.

Drain the water system when appropriate if it is not used over a long period. Or you can simply add proper amount of antifreeze into the water system of the unit.

#### NOTE

- Mixing water with glycol will affect the unit performance.
- Please pay attention to the safety instructions attached to the glycol container.

## 5.5 Electrical connection

#### NOTE

- Make sure that the power supply falls within the range of 220-240V~1ph 50Hz/60Hz and is able to provide enough wattage for the unit. The power supply system must comply with the current national safety regulations.
- The electrical connection must be completed by qualified professionals and must comply with local laws and regulations. The company is not responsible for personal or property damage resulting from any incorrect electrical connections.
- Provide dedicated and suitable leakage protection device for the unit, with a minimum distance of 3 mm among the wiring contacts. The unit must be grounded reliably.
- Make sure that the power cord has a large-enough cross section to withstand the maximum current required. Never use a damaged cable.
- Perform electrical connections according to the wiring nameplate (Figure 5-20 or Figure 5-22) of the unit.
- Secure the cable using clamps in the electric control box to ensure the safety of the power supply cable and the connection cable.
- Do not pull, step on or squeeze the cable. Do not use nails or staples to secure the power cord.
- The cable must be passed through the knockout hole at the foundation.
- An AC contact switch (with contact separation of at least 3mm) must be installed on the fixed wiring to disconnect the machine from the electrical mains and the omnipolar switch.

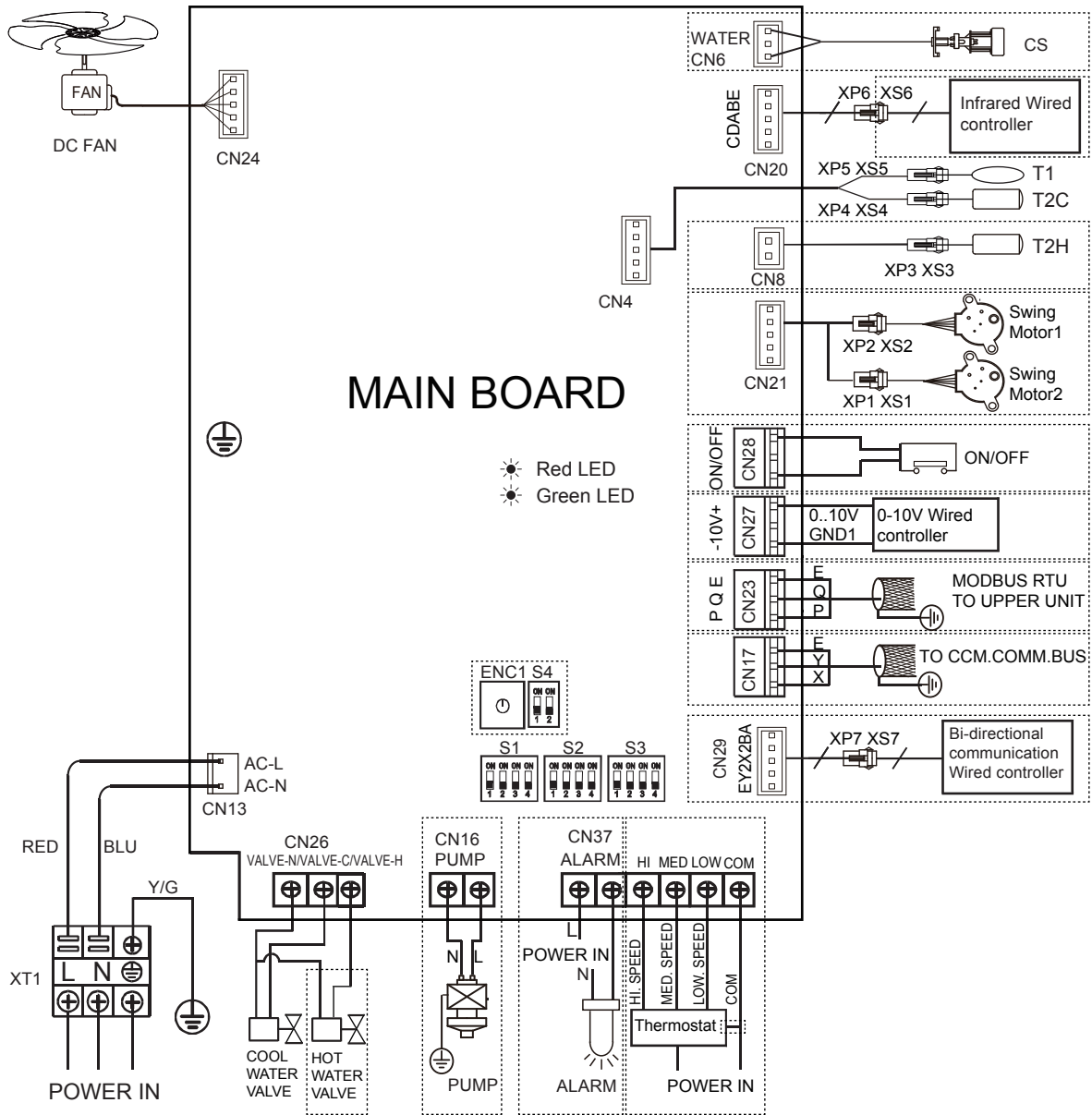


Figure 5-20 Wiring diagram (unit with inverter motor I-VM; I-VN)

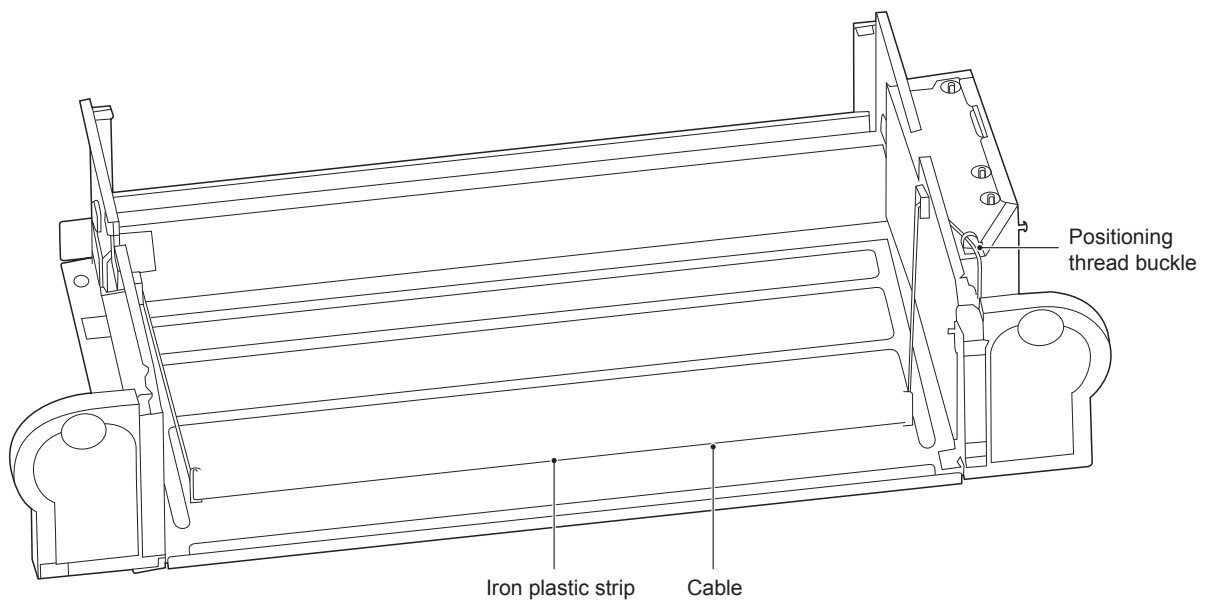


Figure 5-21 Cabling diagram (unit with inverter motor I-VM; I-VN)



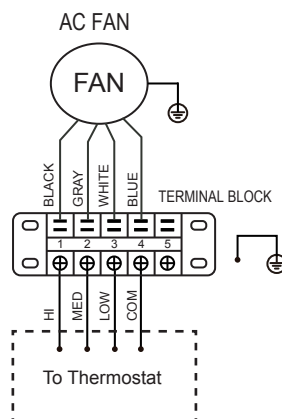


Figure 5-22 Wiring diagram (version 3V-VM; 3V-VN)

The grounding wire in the electrical control box needs to be longer than the current-carrying wire.

Refer to Table 5-2 and Table 5-3 for the specifications of the power cord and communication wire. A wiring capacity that is too small will cause the electrical wiring to become too hot, and result in accidents when the unit burns and becomes damaged.

Select the wire diameters (minimum value) individually for each unit based on Table 5-3.

The maximum allowable voltage range variation between phases is 2%.

Select the circuit breaker that has a contact separation of no less than 3 mm in all poles to provide full disconnection. MFA is used to select the current circuit breakers and residual current operation breakers:

Table 5-2

Model		ALL
Power supply	Phase	1-phase
	Volt and frequency	220-240V~50/60Hz
Communication wire between IDU and wired controller *		Shielded ×AWG16-AWG18
CIRCUIT BREAKER/FUSE (A)		15/15

Please refer to the corresponding wired controller manual for the wired controller wiring.

Table 5-3

Rated current of appliance(A)	Nominal cross-sectional area (mm <sup>2</sup> )	
	Flexible cords	Cable for fixed wiring
≤ 3	0.5 and 0.75	1 and 2.5
>3 and ≤ 6	0.75 and 1	1 and 2.5
>6 and ≤ 10	1 and 1.5	1 and 2.5
>10 and ≤ 16	1.5 and 2.5	1.5 and 4
>16 and ≤ 25	2.5 and 4	2.5 and 6
>25 and ≤ 32	4 and 6	4 and 10
>32 and ≤ 50	6 and 10	6 and 16
>50 and ≤ 63	10 and 16	10 and 25

## 5.6 Startup guide

Machine commissioning or first start-up must be performed by a professional.

Before startup, make sure that the installation and electrical connections are made in accordance with this Manual, and that no unauthorized personnel is near the machine during operation.

### 1) Before starting the unit, make sure that:

The device is positioned correctly.

The water system's flow and piping are correct.

The water pipe is clean.

The air can flow normally.

The condensate water can flow normally to the drain outlet and the elbow.

The heat exchanger is clean.

The electrical connection is correct.

The connecting cable is secure.

The power supply meets requirements.

The motor works normally within the allowable value.

## 6 SERVICE GUIDE

Ask a professional technician to repair a faulty unit.

Make sure the power supply is disconnected during repair.

### 6.1 Troubleshooting

The warranty does not cover the damage caused by dismantling or cleaning of the internal components by unauthorized agents.

#### WARNING

When any unusual situations arises (burning odour, etc.), stop the unit immediately and turn off the power.

If there is any damage, such as electric shock or fire, caused by the unit, contact your dealer.

The system maintenance must be carried out by qualified maintenance personnel.

Error	Countermeasure
A safety device, such as a fuse, circuit breaker or a leakage circuit breaker is triggered frequently, or the ON/OFF switch is not working properly.	Turn off the main power switch.
The operating switch is not functioning normally.	Turn off the power supply.
When a centralized controller is used, the unit number is displayed on the user interface, the operating indicator is flickering, and an error code is shown on the screen as well.	Notify the installation personnel and report the error code.

If the error occurred does not fall within those described in the above table, follow the steps below.

Error	Countermeasure
The system does not run at all.	Check whether there is a power failure. Wait for the power supply to be restored. If a power failure occurs during unit running, the system will restart automatically once the power is restored.
The system is running but there is insufficient cooling or heating.	<p>Check whether the air outlet is blocked by any obstacles. If any, remove the obstacles.</p> <p>Check whether the filter is blocked.</p> <p>Check the temperature setting.</p> <p>Check the fan speed settings on the user interface.</p> <p>Check whether the doors and windows are open.</p> <p>Close the doors and windows to shut out wind from the external environment.</p> <p>Check whether there are too many people in the room when the unit is running in Cool mode.</p> <p>Check whether there is too much heat dissipated from any heat source in the room.</p> <p>Check whether there is direct sunlight into the room.</p> <p>Use curtains or blinds.</p> <p>Check whether the angle of air flow is appropriate.</p>

## 1) Error code overview

If a centralized controller is used, error codes (if any) will appear on the user interface. Contact the installation personnel and inform them of the error code, unit model and serial number (you can find the information on the nameplate of this unit).

NO.	Error	Name	Running Indicator	Fault Indicator	Buzzer Action	Error Code
1	Error	E <sup>2</sup> PROM communication error	Steady on	Flashes once every 3 seconds	Buzzes twice every 3 seconds	E7
2	Error	Room temperature sensor port exception	Steady on	Flashes twice every 3 seconds	Buzzes twice every 3 seconds	E2
3	Error	Coil sensor (T2C) port exception	Steady on	Flashes 3 times every 3 seconds	Buzzes twice every 3 seconds	E3
4	Error	Coil sensor (T2C) port exception	Steady on	Flashes 3 times every 3 seconds	Buzzes twice every 3 seconds	E4
5	Error	DC motor stall fault	Steady on	Flashes 4 times every 3 seconds	Buzzes twice every 3 seconds	E8
6	Protection	Water level exceeding warning line	Blinking	Flashes once every 3 seconds	Buzzes twice every 3 seconds	EE
7	Protection	Model protection not set (DIP switch of the unit not listed in the model table)	Blinking	Flashes twice every 3 seconds	Buzzes twice every 3 seconds	PH
8	Protection	Water temperature protection	Blinking	Flashes 3 times every 3 seconds	Buzzes twice every 3 seconds	P1
9	Protection	Anti-freezing protection	Blinking	Flashes 4 times every 3 seconds	Buzzes twice every 3 seconds	P0
10	Protection	Remote shutdown	Blinking	Flashes 5 times every 3 seconds	Buzzes twice every 3 seconds	P2

Refer to Maintenance Manual for troubleshooting.

## 6.2 Non-unit related faults

The following fault symptoms are not caused by the unit itself:

### 1) Fault symptom: Fan speed is not consistent with the setting

The fan doesn't respond to the controller. In Cool mode, when the pipe water temperature exceeds the allowable range of room temperature, the fan speed will be maintained at a low level to avoid direct exposure to hot air. In Heat mode, when the pipe water temperature reaches a certain low level, the fan speed will also be maintained at a low level to avoid direct exposure to cold air.

### 2) Fault symptom: Fan direction is not consistent with the setting

The fan direction is inconsistent with that indicated on the user interface. Swing is a customized function. When Swing is enabled but the fan direction does not change accordingly, it is because the unit is responding to other control instructions.

### 3) Fault symptom: white fog from a certain unit

This may result from high humidity during cooling operation. If the fan coil interior is dirty, the indoor temperature distribution may be uneven. At this time, you need to clean the inside of the unit. Ask the dealer for information on how to clean the unit. This operation must be carried out by qualified maintenance personnel.

### 4) Fault symptom: dust and dirt in the unit

This may happen after the unit is used again after being left idle for a long period. This is because there is dust inside the unit.

### 5) Fault symptom: odour from unit

The unit will absorb odours of rooms, furniture, cigarettes, etc., and then disperse the odours. Odours might occur after small animals enter the unit.

## 6.3 Product data

Table 6-1

Model	150-I	250-I	350-I
Air flow volume (m <sup>3</sup> /h)	255	400	595
Cooling capacity (kW) (*)	1.50	2.35	3.80
Heating capacity (kW) (**)	1.57	2.60	3.50
Sound pressure (dB(A)) (***)	34	29	38
Rated input (W)	15	17	26
Rated current (A)	0.18	0.20	0.26
Standard coil connections	G3/4		
Condensation drain pipe connection	ODΦ18.5mm		
Power supply	220-240V~50Hz		

Model	500-I	700-I	800-I
Air flow volume (m <sup>3</sup> /h)	790	1190	1360
Cooling capacity (kW) (*)	4.30	5.60	7.35
Heating capacity (kW) (**)	4.70	6.00	8.05
Sound pressure (dB(A)) (***)	46	50	52
Rated input (W)	50	96	113
Rated current (A)	0.49	0.85	0.95
Standard coil connections	G3/4		
Condensation drain pipe connection	ODΦ18.5mm		
Power supply	220-240V~50Hz		

Model	150-3V	250-3V	350-3V
Air flow volume (m <sup>3</sup> /h)	255	400	595
Cooling capacity (kW) (*)	1.65	2.65	3.85
Heating capacity (kW) (**)	1.85	3.05	4.10
Sound pressure (dB(A)) (***)	35	34	39
Rated input (W)	35	47	51
Rated current (A)	0.15	0.20	0.22
Standard coil connections	G3/4		
Condensation drain pipe connection	ODΦ18.5mm		
Power supply	220-240V~50Hz		

Model	500-3V	700-3V	800-3V
Air flow volume (m <sup>3</sup> /h)	790	1190	1300
Cooling capacity (kW) (*)	4.65	6.00	7.35
Heating capacity (kW) (**)	5.20	6.15	8.20
Sound pressure (dB(A)) (***)	48	50	50
Rated input (W)	91	123	123
Rated current (A)	0.40	0.53	0.53
Standard coil connections	G3/4		
Condensation drain pipe connection	ODΦ18.5mm		
Power supply	220-240V~50Hz		

(\*) Conditions: ambient temperature 27°C DB/19°C WB; water inlet temperature 7°C; water outlet temperature 12°C; maximum speed

(\*\*) Conditions: ambient temperature 20°C DB/15°C WB; water inlet temperature 45°C; water outlet temperature 40°C; maximum speed

(\*\*\*) The sound pressure level in dB(A) indicates the value measured at 1 m away from an open air outlet.

The sound pressure level is below 70 dB.